

GATE VALVE RISING STEM OS&Y

Valves are manufactured and tested in accordance with BS EN 1171 PN 10 /16 /25, TIS 432 PN 6 /10 /16 and also meet the requirements of MSS-SP-70 class 125/250, Suitable for all types of water, air and steam.

SIZE: 50 mm - 2400 mm



Fig.110



Fig.112

FEATURES

- IBBM (iron body and bronze mounted), stainless steel trim, and all iron trim is also available.
- Valve ends can be flanged or screwed.
- Flanged drilling to suit ANSI B 16.1, BS EN 1092-2, BS 10, ISO 2531, AS 2129, DIN, JIS, FLANGE ANSI B 16.5 CL.300, and etc.
- Various types of operators such as handwheel, chainwheel, spur gear, bevel gear, pneumatic, hydraulic and electric actuator can be provided upon requested.
- Special accessories like by-pass unit, valve locking device, tapped bosses, drain plug, pipe cover, indicator and limit switches are also available.
- Coating Fusion Bond Epoxy.

DIMENSIONS AND MATERIALS

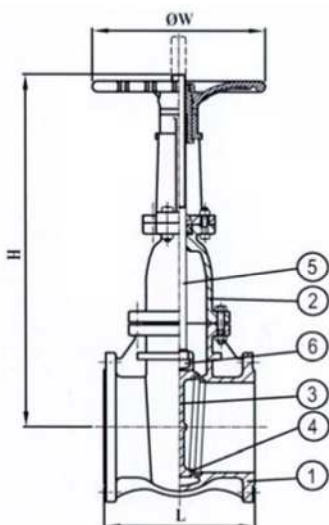

Fig.110

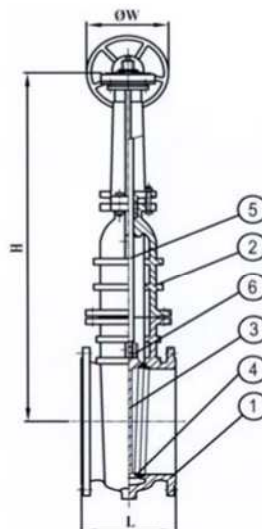

Fig.112

SIZE DN	L (mm.)		H (mm.)	ØW (mm.)	APPROX. WEIGHT(kg.)			No OF TURN
	PN 10/16	PN25			PN10	PN16	PN25	
50	178	216	293	160	13	13	14	13
65	190	241	318	180	17	17	19	16.5
80	203	283	368	198	24	24	27	20
100	229	305	450	250	39	39	44	25
125	254	381	511	280	51.5	51.5	61	26
150	267	403	614	300	68	68	84	31
200	292	419	764	355	113	127	136	41
250	330	457	919	395	170	174	203	51
300	356	502	1061	450	238	242	293	49
350	381	572	1278	450	375	391	470	57
400	406	610	1513	700	603	622	716	65
450	432	660	1643	700	690	722	833	73
500	457	711	1800	700	917	968	1103	81
600	508	787	2115	700	1378	1470	1636	97.5

SIZE DN	L (mm.)		H (mm.)	ØW (mm.)	APPROX. WEIGHT(kg.)			No OF TURN
	PN 10/16	PN25			PN10	PN16	PN25	
350	381	572	1325	280	435	451	530	143
400	406	610	1560	450	698	717	811	196
450	432	660	1675	450	784	816	927	220
500	457	711	1855	450	1012	1063	1198	244
600	508	787	2245	500	1900	1992	2158	390
700	610	-	2448	500	2314	2383	-	341
750	610	-	2563	500	2540	2609	-	365
800	660	-	2718	500	3560	3640	-	486
900	711	-	2985	500	4114	4214	-	546
1000	811	-	3375	623	4670	4818	-	810
1050	811	-	3760	623	5230	5388	-	820
1200	838	-	4140	623	5780	5968	-	970
1400	860	-	4530	623	6330	6482	-	1700
1500	900	-	4920	623	6890	7131	-	1819

NO.	PARTS NAME	MATERIAL	ASTM. DESIGNTION	BS. STANDARD
1	Body	Cast Iron	A 126 Class B	EN1561-EN-GJL-250
2	Bonnet	Ductile Iron	A 536 Grade 65-45-12	EN1563-EN-GJS-500-7
3	Disc		A 536 Grade 80-55-6	
			A 395	
4	Seat	Bronze	B 62	EN1982-CC491K
		Stainless Steel	A 276 Type 304, 316, 431	970 Grade 304, 316, 431
		Aluminium Bronze	B 148 C95200	EN12420-CW307G
5	Stem	High Tensile Brass	B 16, B 21	EN12165-CW721R(CZ114)
		Stainless Steel	A 276 Type 304, 316, 431	970 Grade 304, 316, 431
		Aluminium Bronze	B 124	EN12420-CW307G(CZ104)
			B 132	
6	Stem Nut	Aluminium Bronze	B 148 C95200	EN12420-CW307G(CZ104)
		Bronze	B 62	EN1982-CC491K
		Stainless Steel	A 276 Type 304, 316, 431	970 Grade 304, 316, 431



SCI CORPORATION Co.,Ltd.

Factory: 1/12 Moo 2, Samutsakorn Industrial Estate, Soi 7,
 Rama 2 Road, Tahsai, Muang, Samutsakorn 74000, Thailand
 Tel: (6634)440-130 Fax: (6634)440-137 E-mail: sci@scivalve.com



ISO 9001:2015
 File No.438881 QM
 ISO 14001:2015
 File No.438881 UM